



**ZVA1000 is a series of high quality actuators intended for control of chilled water or hot water valves.**

- \* Modulating control 0(2)-10VDC, 0(4)-20mA
- \* Robust enclosure, with large LED indicator
- \* Manual override
- \* Automatic stroke adjustment

### Function

The ZVA1500 is a series of valve actuators intended for the most common plug type of control valves available in the market.

Modulating model can accept either voltage or current input signal. A feedback signal of 0-10 VDC is provided for interfacing to position indicators. LED indicator displaying the valve position on the side of housing provides a easy to read feedback.

#### Field of application

The actuator is used to operate valves for chilled water, hot water and steam applications.

#### Manual Override

Manual override is available as standard. The gearing can be disengaged by simply lifting the wing nut on the top of the housing. While the wing nut is lifted, the actuator can be set to any position. See next page.

#### Improved functional safety

The actuator of the modulating type has built in torque switches for overload protection. It stops automatically when it reaches the actuator end stop. The stroke can be automatically adjusted at site and is pre-calibrated in the factory for 20mm travel.

#### Simple installation

The actuator is fitted with a universal U clamp for quick and easy mounting directly on the valve connector. Coupling nuts can be provided for all type of connection - mushroom head or screw joints. Red and blue indicators on the linkage bracket provide visual indication of the valve position.

Note: The valve actuator can be adapted on valves of the brands. Please consult factory for full range of accessories for adapting onto valves of other make.

### Model

	<b>Control signal</b>	<b>Supply voltage</b>	<b>Force</b>
<b>ZVA1500-24ED</b>	0-10 VDC, 2-10 VDC, 0-20 mA, 4-20 mA	24 VAC	1500 N

## Technical Data

Supply voltage	24 VAC	Ambient temperature	2...55°C
Control signal	0(2)... 10 VDC, 0(4)...20 mA	Storage temperature	-20...65°C
Transformer sizing	2.5 VA	Ambient humidity	90%
Stroke	20 mm preset	Cable connection	Screw terminals
Stroke time	50Hz: 7.77sec/mm 60Hz: 6.45sec/mm	Degree of protection	IP54
Force	1500 N	Weight	1.45 Kg

## Dimensions

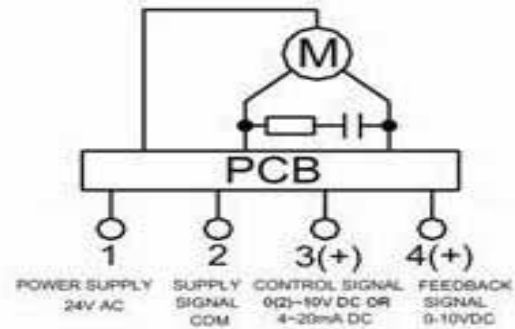
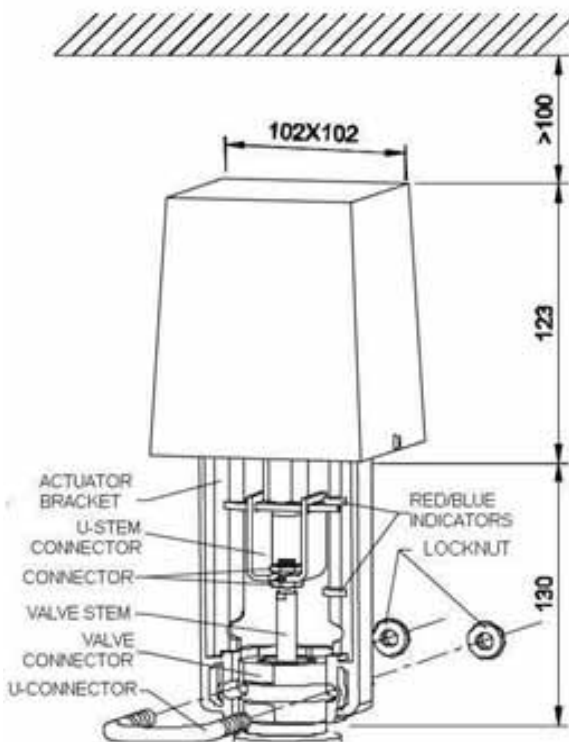

INPUT CONTROL SIGNAL		ACTUATOR ROD
DA	RA	
INCREASE	DECREASE	DOWN
DECREASE	INCREASE	UP

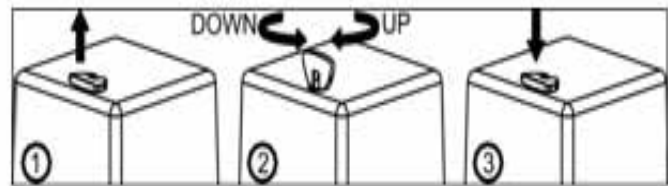

**Calibration:** Set JP1 switch settings as required (see table). Turn the power on. For auto stroking, toggle switch "4" of JP1 to ON, and press SW1 STUDY/REPOSITION button. The buzzer will beep every 5 seconds and the actuator stem will extend (opening) until it has reached the maximum stroke. The actuator will then return back until it has reached the zero position. The buzzer will make a long beep to indicate the calibration process is over. The stroking data will be stored in the CPU non-volatile RAM. Remember to toggle switch "4" of JP1 back to position OFF to revert to running status. If this step is missed, the actuator will operate as usual, but it will go through the calibration stage every time the power is turn on.

**Running status:** The actuator will reposition itself at zero every time the power is on. It will initialise the actuator and when the buzzer makes a long beep, the actuator will response to the control signal.

**Working settings:** If the user needs to change to other working settings, make sure JP1 has been set correctly, then press the SW1 STUDY/REPOSITION button. There is no need to remove power.

### JP1 SWITCH SETTING:

		CONTROL SIGNAL			
STATUS SWITCH		0-10V DC	2-10V DC	0-20mAV DC	4-20mAV DC
RUNNING STATUS	DA				
	RA				
STUDY STATUS	DA				
	RA				

DEFAULT SETTING  
OFF ON

### PCB DIAGRAM

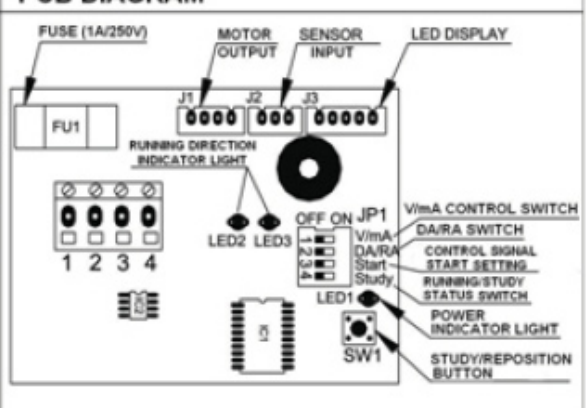

NOTICE: We strongly recommend that JP1 switch should be set on running status in normal use.