



The ZSVD fan coil valve is a high quality valve designed to use with the ZMLA modulating actuator. It is used for modulating control of hot or cold water in heating and cooling HVAC systems. It features a bi-directional synchronous motor for low voltage operation designed for long life trouble free operation. The valves are equipped with spring return mechanism.

- Low cost
- Tight shut-off
- Plastic housing (condensation free)
- Spring loaded valve
- Close-off pressure up to 400 kpa
- Self adjusting (stroking) function

Function

The ZSVD series valves are designed to control heating or cooling water. The ZMLA series of modulating actuators are designed to withstand high moisture conditions found in many concealed installations.

Function

The actuator is driven by a bi-directional synchronous motor with a magnetic clutch. Through the use of the magnetic clutch, the motor can generate stable torque in pause situation. So the motor can stop at any point if there is no current passing through it. The actuator can therefore be positioned with an increase or decrease signal. An electronic board converts the modulating signal to the floating signal.

Actuator

The actuator must be protected from water leakage that may damage internal parts and motor. The actuator must not be covered with heat insulation materials.

Installation

The valves are to be mounted according to the flow direction marks on the valves. To ensure tight closure and prevent noise when closing, the valves are to be mounted on the return line of a coil. The 3-way valve is of mixing type and should be mounted on the return line. The valves are recommended to be mounted with the actuator in an upright or side position.

Models

2-way	3-way	Connection	Kv	+Pc	Actuator
ZSVD215	ZSVD315	DN15	Kv2.0	400kPa	ZMLA
ZSVD220	ZSVD320	DN20	Kv2.8	400kPa	ZMLA
ZSVD225	ZSVD325	DN25	Kv4.6	400kPa	ZMLA
ZSVD232	ZSVD332	DN32	Kv8.5	400kPa	ZMLA

Technical Data

VALVES

Valve type	2/3 way piston valve
Pressure class	PN 16 (250 psi)
Fluid temperature	5 to 95°C
Ambient operating temperature	0 to 60°C
Stem stroke	4.5 mm
Leakage	none
Valve body	Forging brass HPb59-1
Stem & spring	stainless steel
Piston	FRPA-66
Valve packing	Nitrite rubber

ACTUATORS

Supply voltage	24VAC
Power consumption	3VA (24V)
Ambient operating temperature	2 to 55 °C
Motor	bi-directional synchronous
Force	200 N
Full stroke	8 mm
Signal inputs	0-10VDC, 2-10VDC, 0-20mA, 4-20mA
Connector	M30 x 1.5
Positioning time	50Hz: 10sec/mm 60Hz: 8.3sec/mm
Protection class	IP40
Weight	0.32 kg
Chassis & cover	Fire retardant ABS plastic

Dimensions

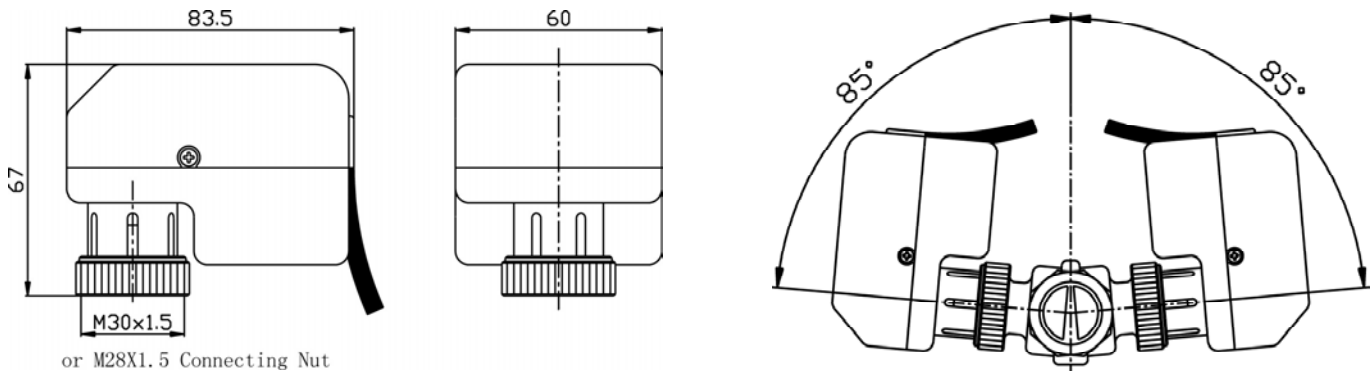

Wiring Diagram

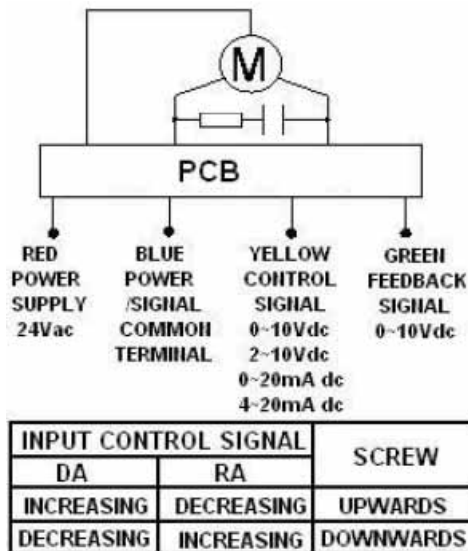

		JP1 SWITCH SETTING:				DEFAULT SETTING
		CONTROL SIGNAL	0~10V DC	2~10V DC	0~20mAV DC	
RUNNING STATUS	STATUS SWITCH	OFF ON	OFF ON	OFF ON	OFF ON	OFF ON 1 2 3 4
	DA	<input type="checkbox"/> OFF <input type="checkbox"/> ON 1 2 3 4	<input type="checkbox"/> OFF <input type="checkbox"/> ON 1 2 3 4	<input type="checkbox"/> OFF <input type="checkbox"/> ON 1 2 3 4	<input type="checkbox"/> OFF <input type="checkbox"/> ON 1 2 3 4	
RA	<input type="checkbox"/> OFF <input type="checkbox"/> ON 1 2 3 4	<input type="checkbox"/> OFF <input type="checkbox"/> ON 1 2 3 4	<input type="checkbox"/> OFF <input type="checkbox"/> ON 1 2 3 4	<input type="checkbox"/> OFF <input type="checkbox"/> ON 1 2 3 4		
STUDY STATUS	DA	<input type="checkbox"/> OFF <input type="checkbox"/> ON 1 2 3 4	<input type="checkbox"/> OFF <input type="checkbox"/> ON 1 2 3 4	<input type="checkbox"/> OFF <input type="checkbox"/> ON 1 2 3 4	<input type="checkbox"/> OFF <input type="checkbox"/> ON 1 2 3 4	
	RA	<input type="checkbox"/> OFF <input type="checkbox"/> ON 1 2 3 4	<input type="checkbox"/> OFF <input type="checkbox"/> ON 1 2 3 4	<input type="checkbox"/> OFF <input type="checkbox"/> ON 1 2 3 4	<input type="checkbox"/> OFF <input type="checkbox"/> ON 1 2 3 4	

NOTICE: We strongly recommend that JP1 switch should be set on running status in normal use.

Calibration: Set JP1 switch settings as required (see table). Turn the power on. For auto stroking, toggle switch "4" of JP1 to position ON, and press SW1 STUDY/REPOSITION button. The buzzer will beep every 5 seconds and the actuator will go down (opening) until it has reached the maximum stroke. The actuator will then return back until it has reached the zero position. The buzzer will make a long beep to indicate the calibration process is over. The stroking data will be stored in the CPU non-volatile RAM. Remember to toggle switch "4" of JP1 back to position OFF to revert to running status. If this step is missed, the actuator will operate as usual, but it will go through the calibration stage every time the power is turn on.

Running status: The actuator will reposition itself at zero every time the power is on. It will initialise the actuator and when the buzzer makes a long beep, the actuator will reponse to the control signal.

Working settings: If the user needs to change to other working settings, make sure JP1 has been set correctly, then press the SW1 STUDY/REPOSITION button. There is no need to remove power.